

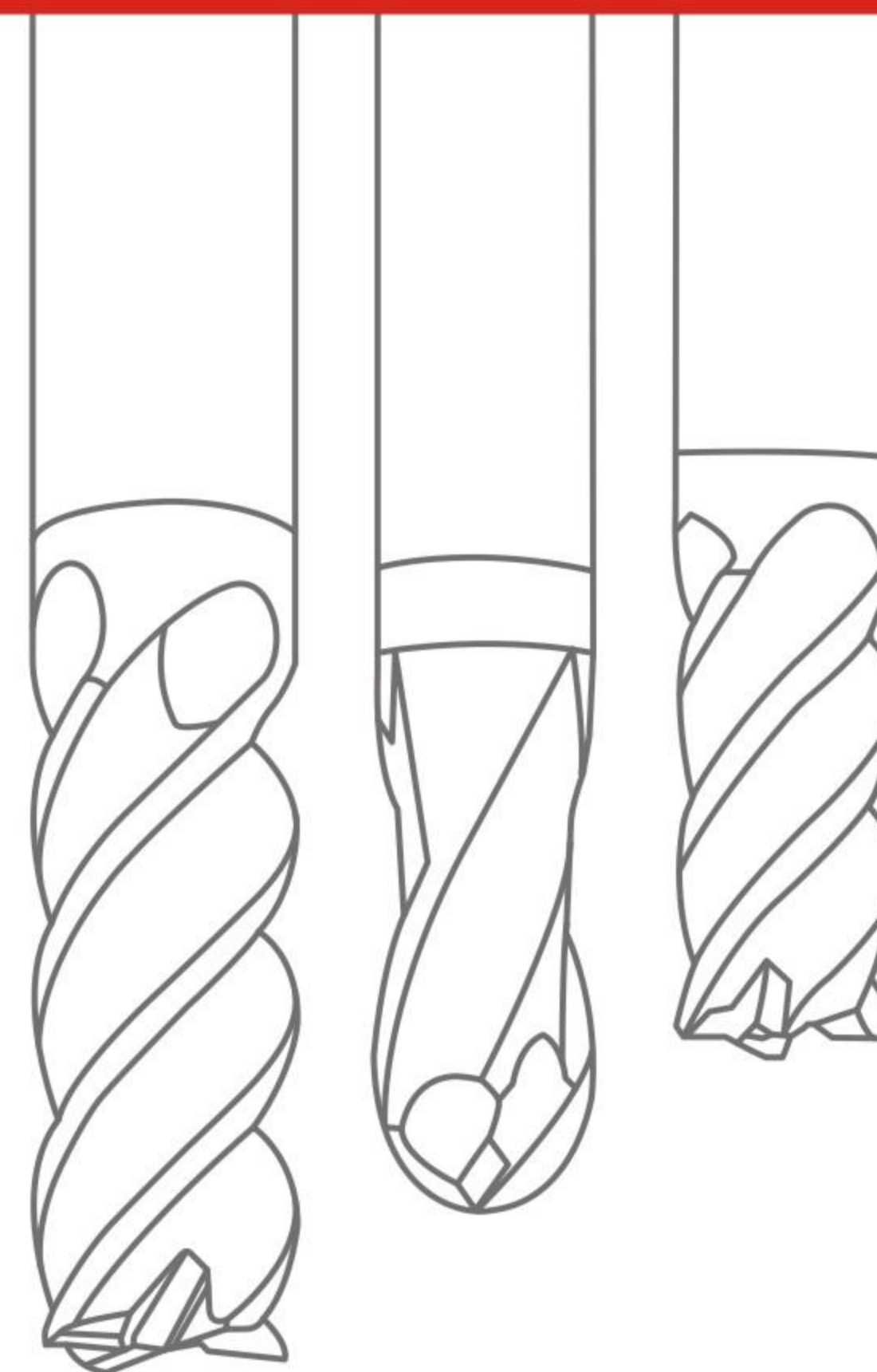

展鸿切削工具有限公司
ZHANHONG CUTTING TOOL CO., LTD.



高品质工具制造商

因为专注·所以专业

MANUFACTURER OF HIGH QUALITY TOOLS
BECAUSE FOCUS · SO PROFESSIONAL

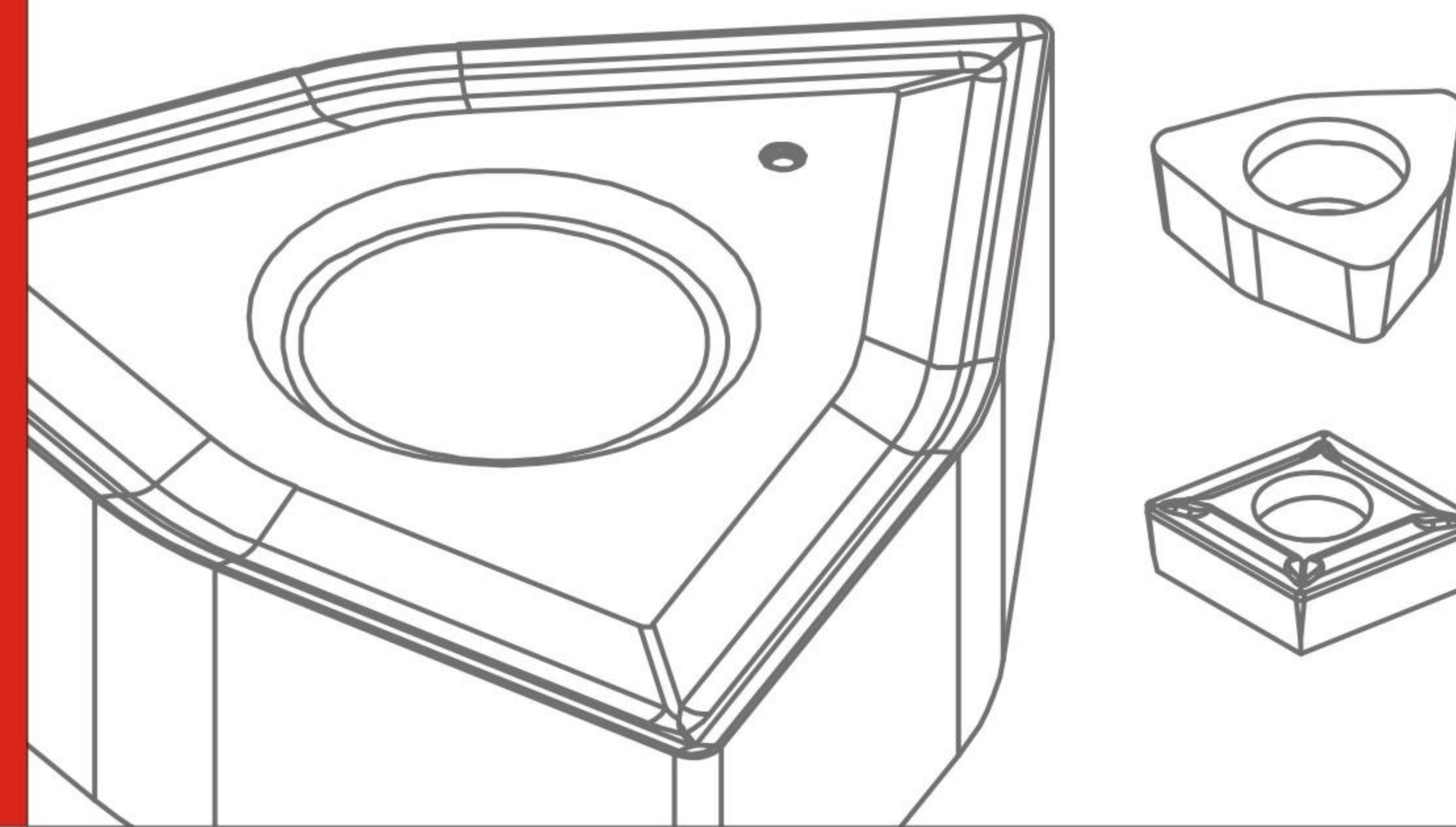
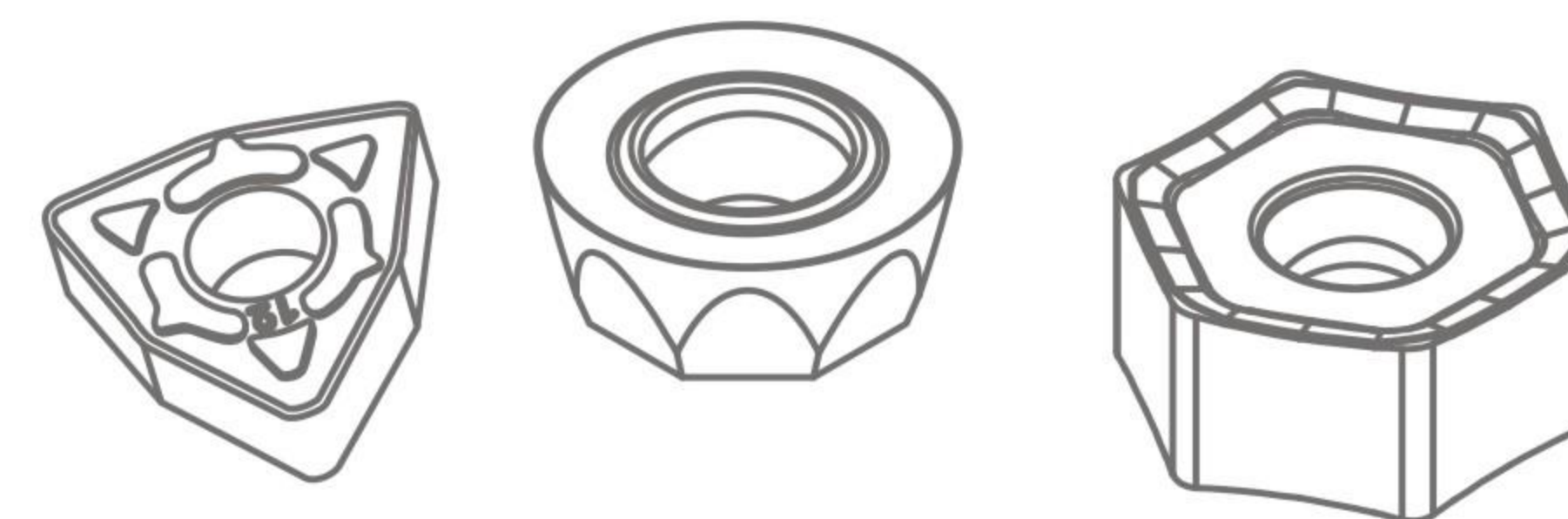

ZANHO TOOL

ACHIEVE OPTIMUM TOOL LIFE

Series index

产品系列 Product series	产品名称 Product name	形状 Shape	尺寸表 Size list
KNA700	不等分抗震铣刀 Unequal Helical End Mill		57
KNA750	多用途铣刀 Multipurpose End Mill		58
KNA800	高硬度模具铣刀 High Hardness Mold End Mill		59
S400	不锈钢专用铣刀 Stainless Steel Special End Mill		61
S460-C	超细微粒钛合金铣刀 Ultrafine Particle Titanium Alloy End Mill		62
S460-C	超细微粒钛合金铣刀 Ultrafine Particle Titanium Alloy End Mill		62
S460-C	超细微粒钛合金铣刀 Ultrafine Particle Titanium Alloy End Mill		62
S650-C	超细微粒航太材料铣刀 Ultrafine Particle Aerospace Material End Mill		63
HRC55	2F/4F-HRC55钨钢铣刀 2F/4F-HRC55 Carbide End mill		65
HRC55	2F-HRC55钨钢球刀 2F-HRC55 Ball nose End Mill		65
HRC55	4F-HRC55钨钢圆鼻刀 4F-HRC55 Corner Radius End Mill		65
HRC60	2F/4F-HRC60钨钢铣刀 2F/4F-HRC60 Carbide End mill		66
HRC60	2F-HRC60钨钢球刀 2F-HRC60 Ball nose End Mill		66
HRC60	4F-HRC60钨钢圆鼻刀 4F-HRC60 Corner Radius End Mill		66
HRC65	2F/4F-HRC65钨钢铣刀 2F/4F-HRC65 Carbide End mill		67
HRC65	2F-HRC65钨钢球刀 2F-HRC65 Ballnose End Mill		67
HRC65	4F-HRC65钨钢圆鼻刀 4F-HRC65 Corner Radius End Mill		67
ZANHO	2F/3F-铝用铣刀 2F/3F-Aluminum End mill		68
ZANHO	2F-铝用球刀 2F-Aluminum Ball nose End mill		68
ZANHO	DLC-U 高效率铝用铣刀 DLC-U Aluminum End mills		68
ZANHO	2F-HRC60小径铣刀-纳米涂层 2F-HRC60 Micro End mill-Nano coating		69
ZANHO	2F-HRC60小径球刀-纳米涂层 2F-HRC60 Micro Ball nose -Nano coating		69
ZANHO	2F-HRC60深沟铣刀 2F-HRC60 Longneck end mill		69
ZANHO	2F-HRC60深沟球刀 2F-HRC60 Long neck Ballnose		69
ZANHO	4F-钢用粗皮刀 4F-Coated Rough End mill		70
ZANHO	3F-铝用粗皮刀 3F-Aluminum Rough Endmill		70
ZANHO	T型铣刀 T-type Endmill		70
ZANHO	燕尾刀 Carbide dovetail Cuitter		70
ZANHO	2F-定点钻 2F-Spot Drill		71
ZANHO	2F-定点钻 2F-Spot Drill		71
ZANHO	内R刀 Inner R Cutter		71
ZANHO	内R刀 Inner R Cutter		71
ZANHO	钨钢抗震车刀杆 Carbide tool holder		72



KNA750

多用途铣刀

MULTIPURPOSE MILLING CUTTER

多功能刀具，适用材料最广泛，工况适应性最优，性价比之王；高速加工，精粗两用，高效率加工。



变螺旋角设计
Variable spiral Angle design

优质复合涂层
High quality composite coating

U型槽设计
U-slot design

优质硬质合金棒材
High quality carbide bars



KNA700

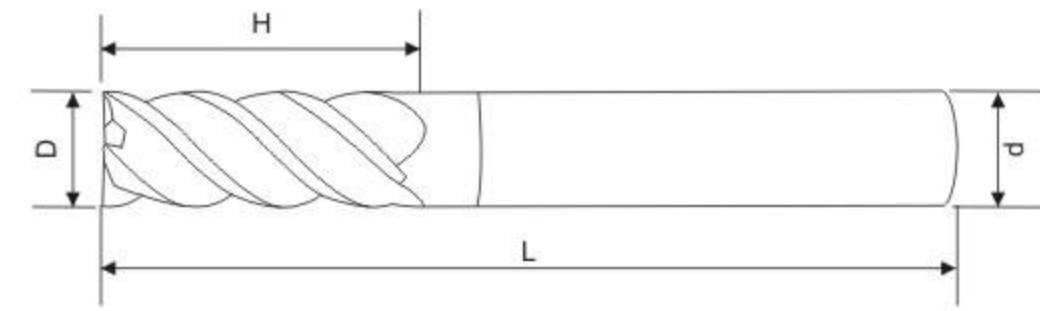

型号 Code	刃径/D	刃长/H	柄径/d	全长/L
D1*D4*50L*4F	1	3	4	50
D1.5*D4*50L*4F	1.5	5	4	50
D2*D4*50L*4F	2	6	4	50
D2.5*D4*50L*4F	2.5	8	4	50
D3*D3*50L*4F	3	9	3	50
D3*D4*50L*4F	3	9	4	50
D3.5*D4*50L*4F	3.5	10	4	50
D4*D4*50L*4F	4	12	4	50
D5*D5*50L*4F	5	13	5	50
D5*D6*50L*4F	5	13	6	50
D6*D6*50L*4F	6	15	6	50
D6*D6*50L*4F	6	18	6	50
D8*D8*60L*4F	8	20	8	60
D8*D8*60L*4F	8	24	8	60
D10*D10*75L*4F	10	25	10	75
D10*D10*75L*4F	10	30	10	75
D12*D12*75L*4F	12	30	12	75
D12*D12*75L*4F	12	35	12	75
D14*D14*100L*4F	14	45	14	100
D16*D16*100L*4F	16	45	16	100
D18*D18*100L*4F	18	45	18	100
D20*D20*100L*4F	20	45	20	100

型号 Code	刃径/D	刃长/H	柄径/d	全长/L
D3*D3*75L*4F	3	12	3	75
D3*D3*100L*4F	3	12	3	100
D4*D4*75L*4F	4	16	4	75
D4*D4*100L*4F	4	20	4	100
D5*D5*75L*4F	5	18	5	75
D5*D5*100L*4F	5	30	5	100
D6*D6*75L*4F	6	24	6	75
D6*D6*100L*4F	6	30	6	100
D8*D8*75L*4F	8	25	8	75
D8*D8*100L*4F	8	35	8	100
D10*D10*100L*4F	10	40	10	100
D12*D12*100L*4F	12	45	12	100
D6*D6*150L*4F	6	45	6	150
D8*D8*150L*4F	8	50	8	150
D10*D10*150L*4F	10	55	10	150
D12*D12*150L*4F	12	55	12	150
D14*D14*150L*4F	14	70	14	150
D16*D16*150L*4F	16	80	16	150
D18*D18*150L*4F	18	80	18	150
D20*D20*150L*4F	20	80	20	150

▶ 被加工材料适合表 The material to be processed fits the table

◎ 非常合适 (Most Suitable) ○ 合适 (suitable)

加工材料 Processing material							
P	M	K	H		N	S	
碳素钢, 合金钢 Carbon steel Alloy steel	不锈钢 Stainless steel	铸铁 球墨铸铁 Cast iron Nodular cast iron	淬火钢 Harden steel (45-55HRC)	淬火钢 Harden steel (55-65HRC)	铜合金 Copper alloy	铝合金 Aluminium alloy	钛合金, 耐热合金 Titanium alloy heat-resistant alloy
◎	○	○					

KNA750

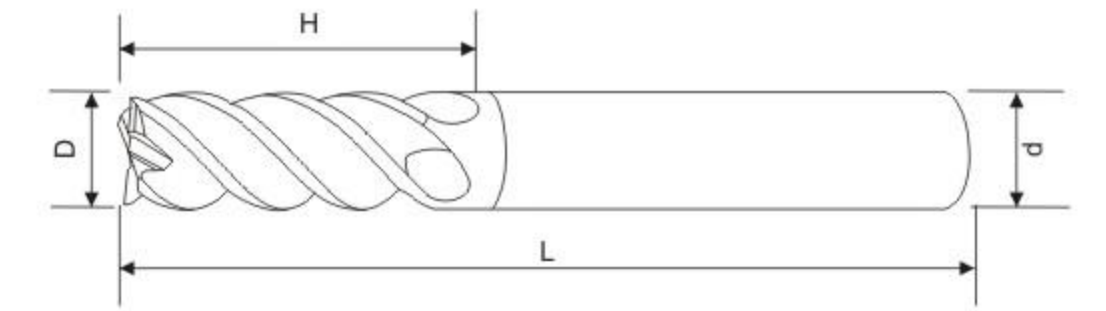

型号 Code	刃径/D	刃长/H	柄径/d	全长/L
D1*D4*50L*4F	1	3	4	50
D1.5*D4*50L*4F	1.5	5	4	50
D2*D4*50L*4F	2	6	4	50
D2.5*D4*50L*4F	2.5	8	4	50
D3*D3*50L*4F	3	9	3	50
D3*D4*50L*4F	3	9	4	50
D3.5*D4*50L*4F	3.5	10	4	50
D4*D4*50L*4F	4	12	4	50
D5*D5*50L*4F	5	13	5	50
D5*D6*50L*4F	5	13	6	50
D6*D6*50L*4F	6	15	6	50
D6*D6*50L*4F	6	18	6	50
D8*D8*60L*4F	8	20	8	60
D8*D8*60L*4F	8	24	8	60
D10*D10*75L*4F	10	25	10	75
D10*D10*75L*4F	10	30	10	75
D12*D12*75L*4F	12	30	12	75
D12*D12*75L*4F	12	35	12	75
D14*D14*100L*4F	14	45	14	100
D16*D16*100L*4F	16	45	16	100
D18*D18*100L*4F	18	45	18	100
D20*D20*100L*4F	20	45	20	100

型号 Code	刃径/D	刃长/H	柄径/d	全长/L
D3*D3*75L*4F	3	12	3	75
D3*D3*100L*4F	3	12	3	100
D4*D4*75L*4F	4	16	4	75
D4*D4*100L*4F	4	20	4	100
D5*D5*75L*4F	5	18	5	75
D5*D5*100L*4F	5	30	5	100
D6*D6*75L*4F	6	24	6	75
D6*D6*100L*4F	6	30	6	100
D8*D8*75L*4F	8	25	8	75
D8*D8*100L*4F	8	35	8	100
D10*D10*100L*4F	10	40	10	100
D12*D12*100L*4F	12	45	12	100
D6*D6*150L*4F	6	45	6	150
D8*D8*150L*4F	8	50	8	150
D10*D10*150L*4F	10	55	10	150
D12*D12*150L*4F	12	55	12	150
D14*D14*150L*4F	14	70	14	150
D16*D16*150L*4F	16	80	16	150
D18*D18*150L*4F	18	80	18	150
D20*D20*150L*4F	20	80	20	150

▶ 被加工材料适合表 The material to be processed fits the table

◎ 非常合适 (Most Suitable) ○ 合适 (suitable)

加工材料 Processing material							
P	M	K	H		N	S	
碳素钢, 合金钢 Carbon steel Alloy steel	不锈钢 Stainless steel	铸铁 球墨铸铁 Cast iron Nodular cast iron	淬火钢 Harden steel (45-55HRC)	淬火钢 Harden steel (55-65HRC)	铜合金 Copper alloy	铝合金 Aluminium alloy	钛合金, 耐热合金 Titanium alloy heat-resistant alloy
◎	◎	◎			○		○

KNA800

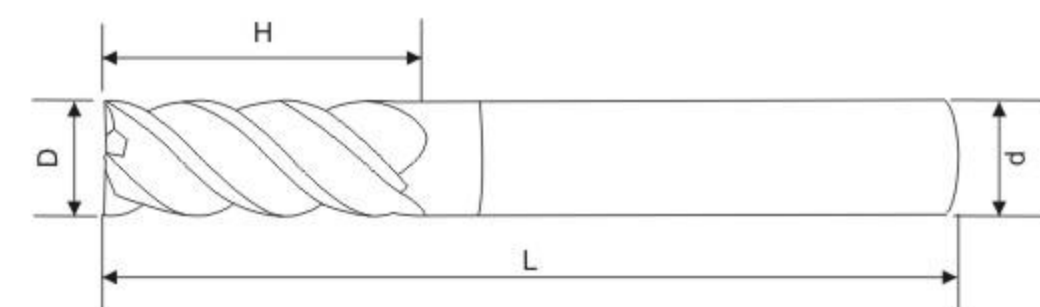

型号 Code	刃径/D	刃长/H	柄径/d	全长/L
D1*D4*50L*4F	1	3	4	4
D1.5*D4*50L*4F	1.5	5	4	4
D2*D4*50L*4F	2	6	4	4
D2.5*D4*50L*4F	2.5	8	4	4
D3*D3*50L*4F	3	9	3	3
D3*D4*50L*4F	3	9	4	4
D4*D4*50L*4F	4	12	4	4
D5*D5*50L*4F	5	13	5	5
D5*D6*50L*4F	5	13	6	6
D6*D6*50L*4F	6	15	6	6
D8*D8*60L*4F	8	20	8	8
D10*D10*75L*4F	10	25	10	10
D12*D12*75L*4F	12	30	12	12
D14*D14*100L*4F	14	45	14	14
D16*D16*100L*4F	16	45	16	16
D20*D20*100L*4F	20	45	20	20

型号 Code	刃径/D	刃长/H	柄径/d	全长/L
D4*D4*75L*4F	4	16	16	4
D4*D4*100L*4F	4	20	20	4
D6*D6*75L*4F	6	24	24	6
D6*D6*100L*4F	6	30	30	6
D8*D8*75L*4F	8	25	25	8
D8*D8*100L*4F	8	35	35	8
D10*D10*100L*4F	10	40	40	10
D12*D12*100L*4F	12	45	45	12
D10*D10*150L*4F	10	55	55	10
D12*D12*150L*4F	12	55	55	12
D14*D14*150L*4F	14	70	70	14
D16*D16*150L*4F	16	80	80	16
D20*D20*150L*4F	20	80	80	20

▶ 被加工材料适合表 The material to be processed fits the table

◎ 非常适合 (Most Suitable) ○ 适合 (suitable)

加工材料 Processing material						
P	M	K	H		N	S
碳素钢, 合金钢 Carbon steel Alloy steel	不锈钢 Stainless steel	铸铁 球墨铸铁 Cast iron Nodular cast iron	淬火钢 Harden steel (45-55HRC)	淬火钢 Harden steel (55-65HRC)	铜合金 Copper alloy	铝合金 Aluminium alloy
			◎	◎		钛合金, 耐热合金 Titanium alloy heat-resistant alloy

S系列 难加工立铣刀

CARBIDE END MILL FOR MACHINING DIFFICULT-TO-CUT MATERIALS

S400: 适合加工不锈钢
S400: suitable for stainless steel

S460-C: 适合加工硬化不锈钢, 钛合金等
S460-C: suitable for hardened stainless steel and Titanium alloy

S650-C: 适合加工航太材料
S650-C: suitable for Aerospace materials

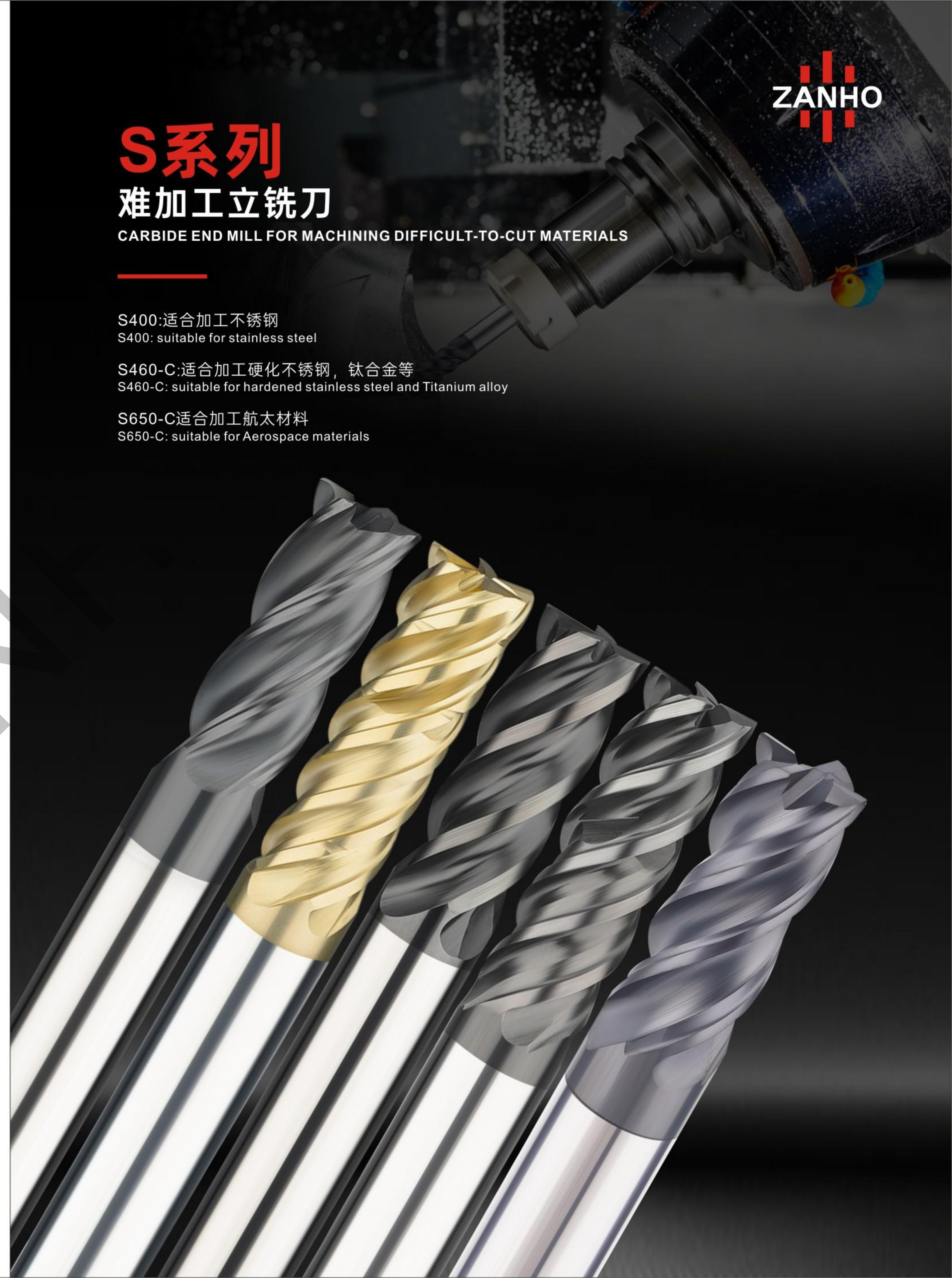

S400

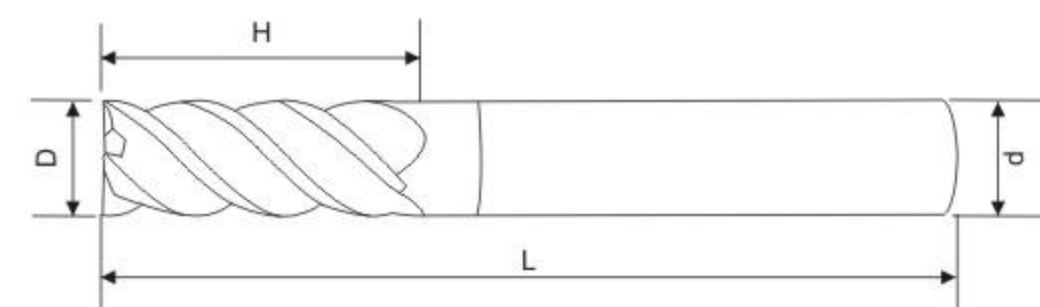

型号 Code	刃径/D	刃长/H	柄径/d	全长/L
D1*D4*50L*4F	1	3	4	50
D1.5*D4*50L*4F	1.5	5	4	50
D2*D4*50L*4F	2	6	4	50
D2.5*D4*50L*4F	2.5	8	4	50
D3*D4*50L*4F	3	9	4	50
D4*D4*50L*4F	4	12	4	50
D5*D6*50L*4F	5	13	6	50
D6*D6*50L*4F	6	15	6	50
D8*D8*60L*4F	8	20	8	60
D10*D10*75L*4F	10	25	10	75
D12*D12*75L*4F	12	30	12	75
D14*D14*100L*4F	14	35	14	100
D16*D16*100L*4F	16	45	16	100

型号 Code	刃径/D	刃长/H	柄径/d	全长/L
D4*D4*75L*4F	4	12	4	75
D6*D6*75L*4F	6	18	6	75
D6*D6*100L*4F	6	18	6	100
D8*D8*75L*4F	8	24	8	75
D8*D8*100L*4F	8	24	8	100
D10*D10*100L*4F	10	30	10	100
D12*D12*100L*4F	12	36	12	100
D16*D16*150L*4F	16	48	16	150

▶ 被加工材料适合表 The material to be processed fits the table

◎ 非常合适 (Most Suitable) ○ 合适 (suitable)

加工材料 Processing material						
P	M	K	H		N	S
碳素钢, 合金钢 Carbon steel Alloy steel	不锈钢 Stainless steel	铸铁 球墨铸铁 Cast iron Nodular cast iron	淬火钢 Harden steel (45-55HRC)	淬火钢 Harden steel (55-65HRC)	铜合金 Copper alloy	铝合金 Aluminium alloy
○	◎	○				○

S460-C

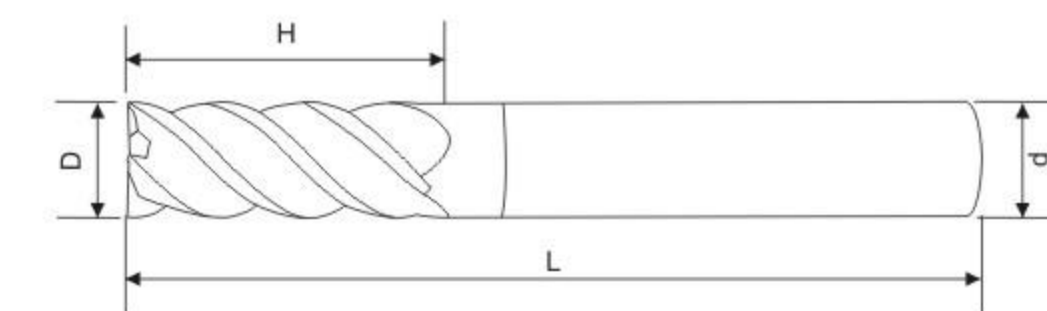

型号 Code	刃径/D	刃长/H	柄径/d	全长/L	C45°
D3*D4*50L*4F	3	9	4	50	0.05
D4*D4*50L*4F	4	12	4	50	0.06
D5*D6*50L*4F	5	13	6	50	0.08
D6*D6*50L*4F	6	15	6	50	0.09
D8*D8*60L*4F	8	20	8	60	0.12
D10*D10*75L*4F	10	25	10	75	0.15
D12*D12*75L*4F	12	30	12	75	0.18
D16*D16*100L*4F	16	45	16	100	0.24
D20*D20*100L*4F	20	45	20	100	0.3

▶ 被加工材料适合表 The material to be processed fits the table

◎ 非常合适 (Most Suitable) ○ 合适 (suitable)

加工材料 Processing material						
P	M	K	H		N	S
碳素钢, 合金钢 Carbon steel Alloy steel	不锈钢 Stainless steel	铸铁 球墨铸铁 Cast iron Nodular cast iron	淬火钢 Harden steel (45-55HRC)	淬火钢 Harden steel (55-65HRC)	铜合金 Copper alloy	铝合金 Aluminium alloy
◎	◎	◎			○	○

S650-C

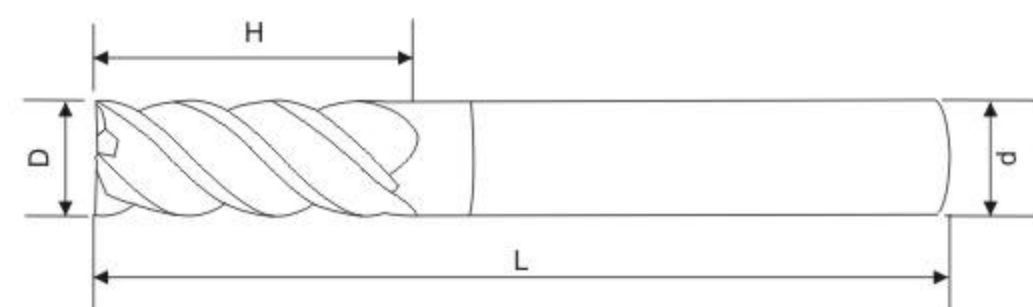

型号 Code	刃径/D	刃长/H	柄径/d	全长/L	C45°
D3*D4*50L*4F	3	9	4	50	0.05
D4*D4*50L*4F	4	12	4	50	0.06
D5*D6*50L*4F	5	13	6	50	0.08
D6*D6*50L*4F	6	15	6	50	0.09
D8*D8*60L*4F	8	20	8	60	0.12
D10*D10*75L*4F	10	25	10	75	0.15
D12*D12*75L*4F	12	30	12	75	0.18
D16*D16*100L*4F	16	45	16	100	0.24
D20*D20*100L*4F	20	45	16	100	0.3

Turning

Milling

Drilling

Grooving

Threading

End Mill

▶ 被加工材料适合表 The material to be processed fits the table ◎ 非常适合 (Most Suitable) ○ 适合 (suitable)

加工材料 Processing material							
P	M	K	H		N	S	
碳素钢,合金钢 Carbon steel Alloy steel	不锈钢 Stainless steel	铸铁 球墨铸铁 Cast iron Nodular cast iron	淬火钢 Harden steel (45-55HRC)	淬火钢 Harden steel (55-65HRC)	铜合金 Copper alloy	铝合金 Aluminium alloy	钛合金, 耐热合金 Titanium alloy heat-resistant alloy
○	○	○					◎



经济型硬质合金铣刀

Economical carbide milling cutter

耐磨耐用，为铣刀使用寿命做出有力保证使用寿命更长。
Wear-resistant and durable, for the milling cutter service life to make a strong guarantee of longer service life.



Economical Carbide End Mill

Economical Carbide End Mill

◎2F/4F-HRC55钨钢铣刀
2F/4F-HRC55 Carbide End mill

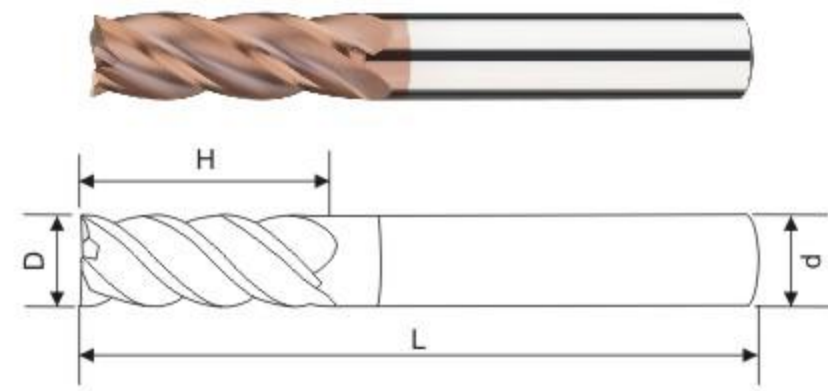

◎2F-HRC55钨钢球刀
2F-HRC55 Ball nose End Mill

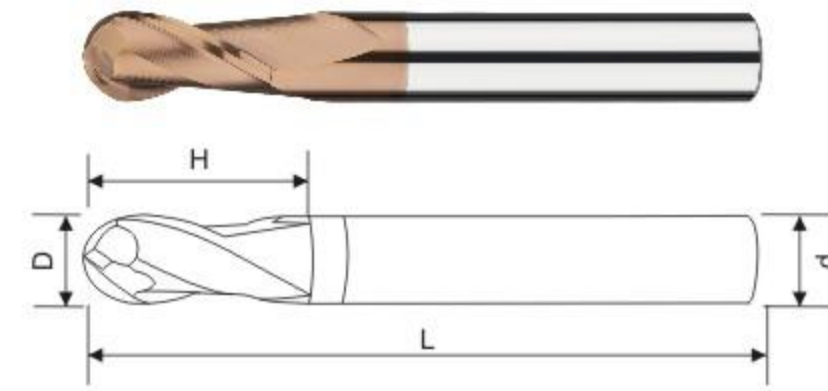

◎4F-HRC55钨钢圆鼻刀
4F-HRC55 Corner Radius End Mill

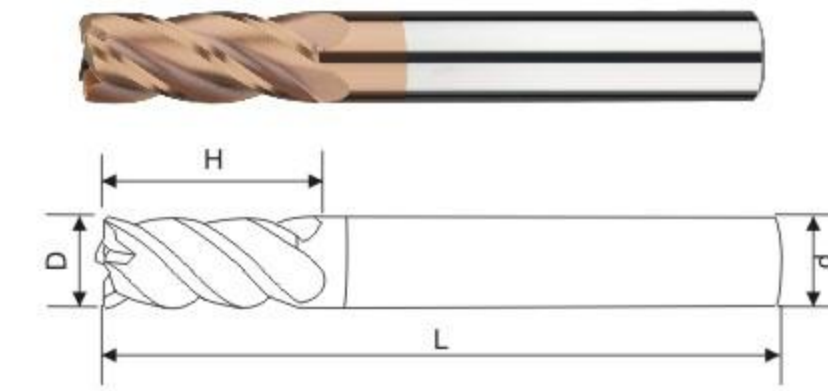

◎2F/4F-HRC60钨钢铣刀
2F/4F-HRC60 Carbide End mill

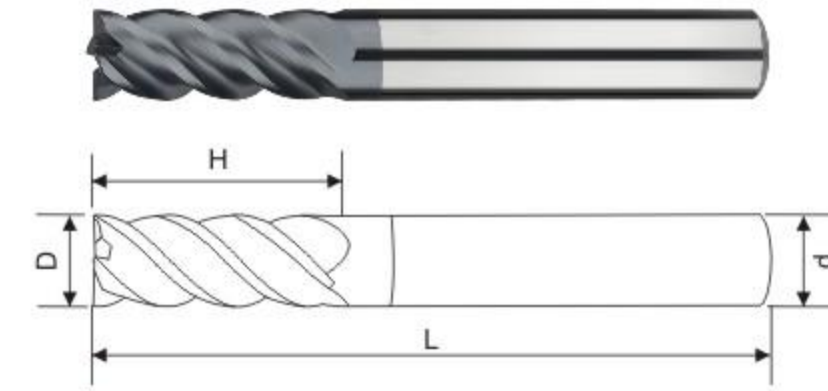

◎2F-HRC60钨钢球刀
2F-HRC60 Ball nose End Mill

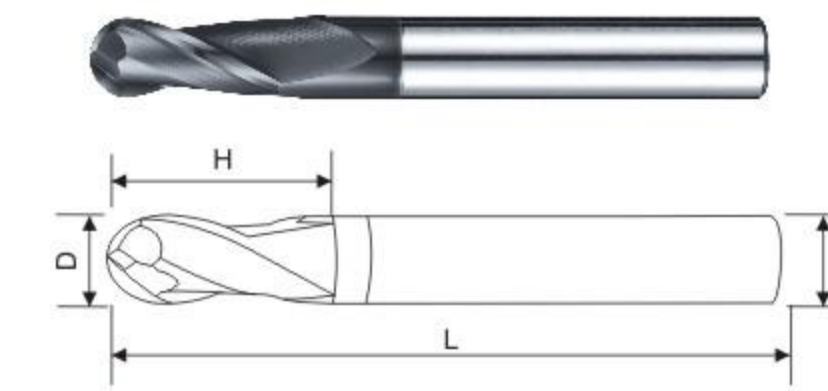

◎4F-HRC60钨钢圆鼻刀
4F-HRC60 Corner Radius End Mill

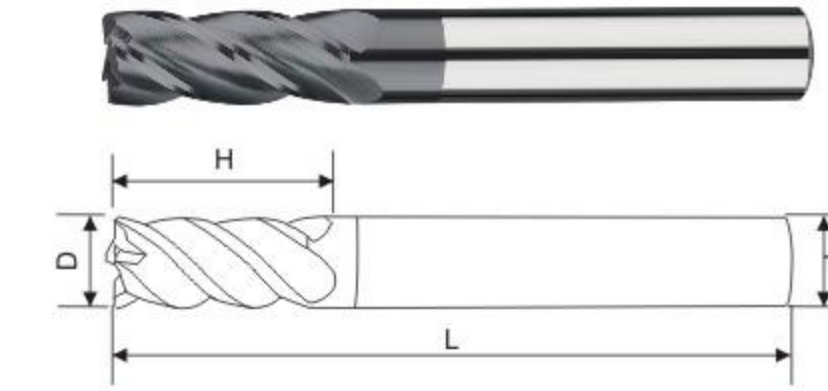

刃径/D	刃长/H	柄径/d	全长/L
1	3	4	50
1	4	4	75
1	5	4	100
1.5	4.5	4	50
1.5	6	4	75
1.5	7	4	100
2	6	4	50
2	8	4	75
2	10	4	100
2.5	7.5	4	50
2.5	10	4	75
3	9	3	50
3	12	3	75
3	15	3	100
3	9	4	50
3	12	4	75
3	15	4	100
3.5	10	4	50
4	12	4	50
4	16	4	75
4	20	4	100
5	15	5	50
5	20	5	75
5	25	5	100
5	15	6	50
6	18	6	50
6	24	6	75
6	30	6	100
6	45	6	150
8	24	8	60
8	30	8	75
8	35	8	100
8	50	8	150
8	70	8	200
10	30	10	75
10	40	10	100
10	60	10	150
10	70	10	200
12	35	12	75
12	45	12	100
12	60	12	150
12	70	12	200
14	45	14	100
14	70	14	150
16	45	16	100
16	70	16	150
16	100	16	200
18	45	18	100
18	70	18	150
20	45	20	100
20	70	20	150
20	100	20	200

刃径/D	刃长/H	柄径/d	全长/L
R0.5	2	4	50
R0.75	3	4	50
R1	4	4	50
R1.25	5	4	50
R1.5	6	4	50
R1.5	6	3	75
R1.5	6	3	100
R2	8	4	50
R2	8	4	75
R2	8	4	100
R2.5	10	5	50
R2.5	10	5	75
R2.5	10	5	100
R2.5	10	6	50
R3	12	6	50
R3	12	6	75
R3	12	6	100
R3	12	6	150
R4	16	8	60
R4	16	8	75
R4	16	8	100
R4	16	8	150
R5	20	10	75
R5	20	10	100
R5	20	10	150
R6	24	12	75
R6	24	12	100
R6	24	12	150
R7	28	14	100
R7	28	14	150
R8	32	16	100
R8	32	16	150
R9	36	18	100
R9	36	18	150
R10	40	20	100
R10	40	20	150

刃径/D	刃长/H	柄径/d	全长/L
D1R0.2	3	4	50
D1.5R0.2	4.5	4	50
D2R0.2	6	4	50
D2R0.5	6	4	50
D3R0.2	8	4	50
D3R0.5	8	4	50
D3R1	8	4	50
D4R0.2	10	4	50
D4R0.5	10	4	50
D4R0.5	10	4	75
D4R0.5	10	4	100
D4R1	10	6	50
D4R1	10	6	75
D4R1	10	6	100
D6R0.2	15	6	50
D6R0.5	15	6	50
D6R0.5	15	6	75
D6R0.5	15	6	100
D6R1	15	6	50
D6R1	15	6	75
D6R1	15	6	100
D8R0.5	20	8	60
D8R0.5	20	8	75
D8R0.5	20	8	100
D8R1	20	8	60
D8R1	20	8	75
D8R1	20	8	100
D10R0.5	25	10	75
D10R0.5	25	10	100
D10R1	25	10	75
D10R1	25	10	100
D12R0.5	30	12	75
D12R0.5	30	12	100
D12R1	30	12	75
D12R1	30	12	100

刃径/D	刃长/H	柄径/d	全长/L
1	3	4	50
1.5	4.5	4	50
2	6	4	50
2.5	7.5	4	50
3	9	3	50
3	12	3	75
3	15	3	100
3	9	4	50
3.5	9	4	50
4	10	4	50
4	16	4	75
4	20	4	100
5	13	5	50
5	20	5	75
5	25	5	100
5	13	6	50
6	15	6	50
6	24	6	75
6	30	6	100
6	40	6	150
8	20	8	60
8	30	8	75
8	35	8	100
8	50	8	150
8	70	8	200
10	25	10	75
10	40	10	100
10	50	10	150
10	70	10	200
12	30	12	75
12	45	12	100
12	55	12	150
12	70	12	200
14	40	14	100
14	70	14	150
16	45	16	100
16	75	16	150
16	100	16	200
18	45	18	100
18	75	18	150
20	45	20	100
20	75	20	150
20	100	20	200

刃径/D	刃长/H	柄径/d	全长/L
R0.5	2	4	50
R0.75	3	4	50
R1	4	4	50
R1.25	5	4	50
R1.5	6	4	50
R1.5	6	3	75
R1.5	6	3	100
R2	8	4	50
R2	8	4	75
R2	8	4	100
R2.5	10	5	50
R2.5	10	5	75
R2.5	10	5	100
R2.5	10	6	50
R3	12	6	50
R3	12	6	75
R3	12	6	100
R3	12	6	150
R4	16	8	60
R4	16	8	75
R4	16	8	100
R4	16	8	150
R5	20	10	75
R5	20	10	100
R5	20	10	150
R6	24	12	75
R6	24	12	100
R6	24	12	150
R7	28	14	100
R7	28	14	150
R8	32	16	100
R8	32	16	150
R9	36	18	100
R9	36	18	150
R10	40	20	100
R10	40	20	150

刃径/D	刃长/H	柄径/d	全长/L
D1R0.2	3	4	50
D1.5R0.2	4.5	4	50
D2R0.2	6	4	50
D2R0.5	6	4	50
D3R0.2	8	4	50
D3R0.5	8	4	50
D3R1	8	4	50
D4R0.2	10	4	50
D4R0.5	10	4	50
D4R0.5	10	4	75
D4R0.5	10	4	100
D4R1	10	4	50
D4R1	10	4	75
D4R1	10	4	100
D6R0.2	15	6	50
D6R0.5	15	6	50
D6R0.5	15	6	75
D6R0.5	15	6	100
D6R1	15	6	50
D6R1	15	6	75
D6R1	15	6	100
D8R0.5	20	8	60
D8R0.5	20	8	75
D8R0.5	20	8	100
D8R1	20	8	60
D8R1	20	8	75
D8R1	20	8	100
D10R0.5	25	10	75
D10R0.5	25	10	100
D10R1	25	10	75
D10R1	25	10	100
D12R0.5	30	12	75
D12R0.5	30	12	100
D12R1	30	12	75
D12R1	30	12	100

Economical Carbide End Mill

Economical Carbide End Mill

◎2F/4F-HRC65钨钢铣刀
2F/4F-HRC65 Carbide End mill

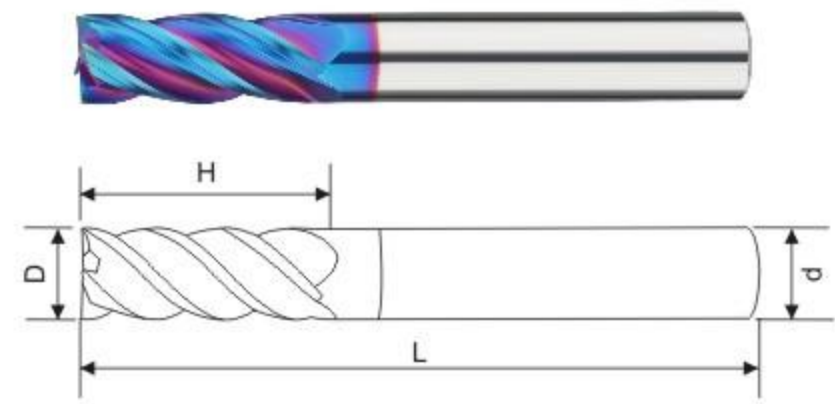

◎2F-HRC65钨钢球刀
2F-HRC65 Ball nose End Mill

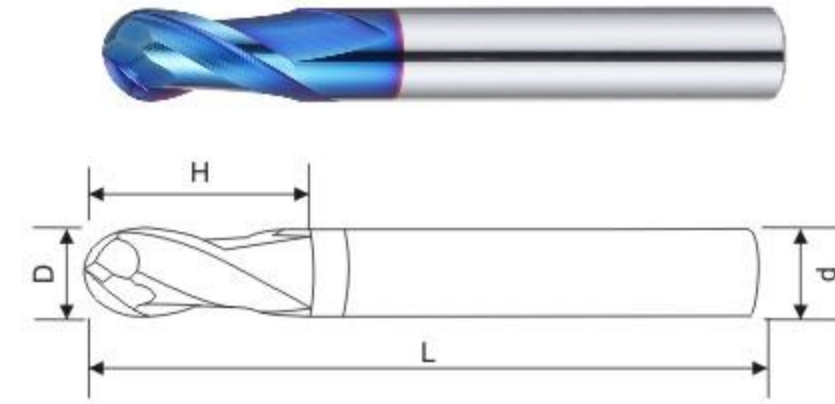

◎4F-HRC65钨钢圆鼻刀
4F-HRC65 Corner Radius End Mill

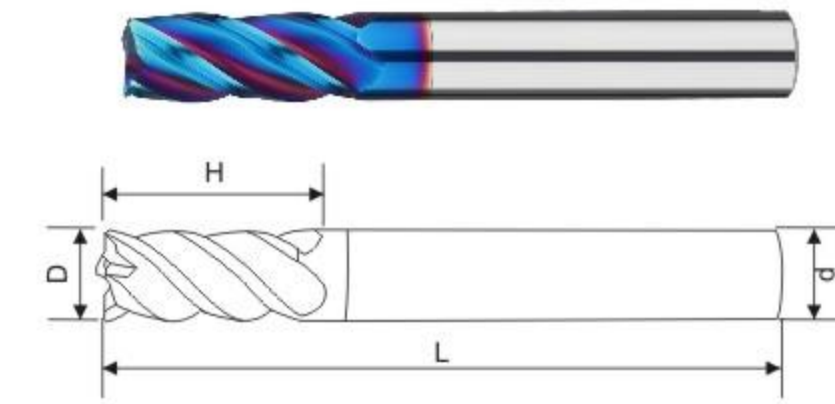

◎2刃/3刃-铝用铣刀
2F/3F-Aluminum End mill

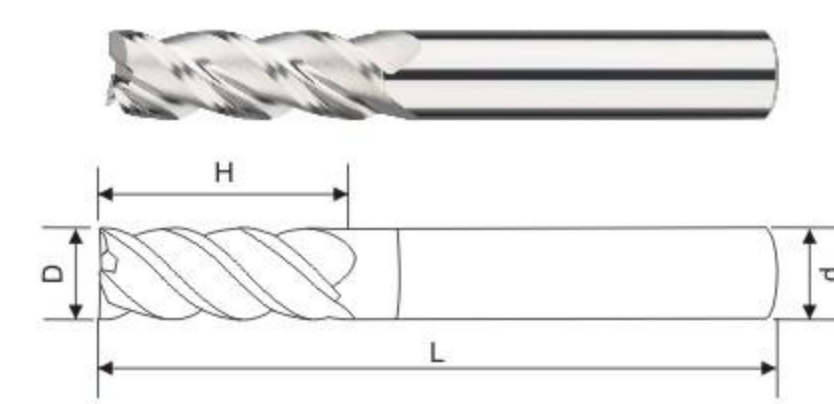

◎2刃-铝用球刀
2F-Aluminum Ball nose End mill

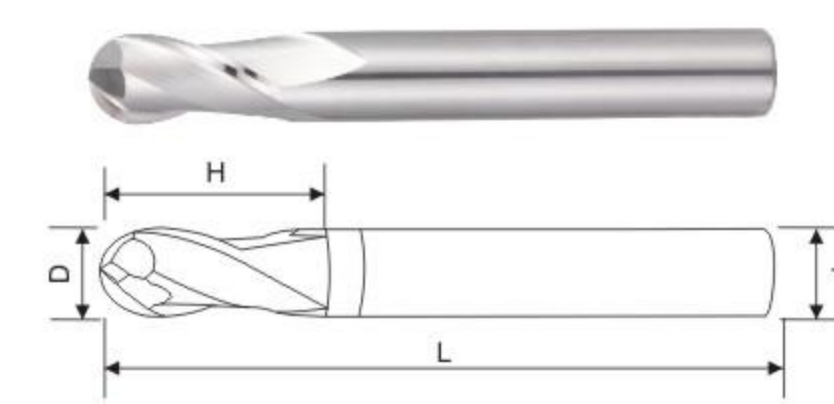

◎DLC-U 高效率铝用铣刀
DLC-U Aluminum End mills

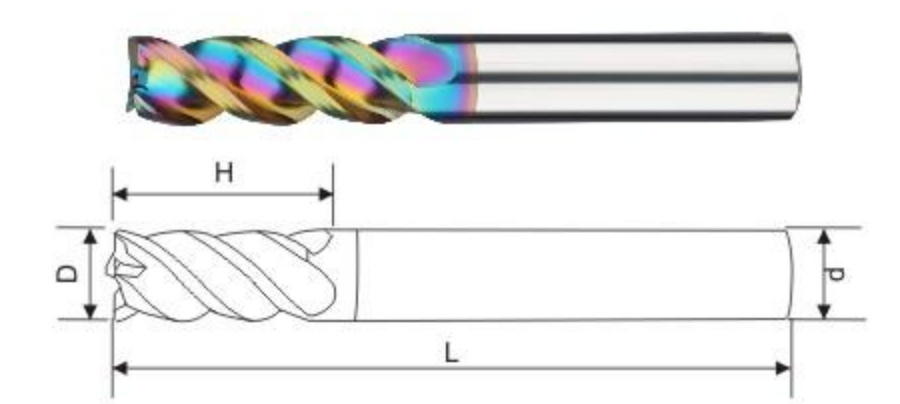

刃径/D	刃长/H	柄径/d	全长/L
1	3	4	50
1.5	4.5	4	50
2	6	4	50
2.5	7.5	4	50
3	9	3	50
3	12	3	75
3	15	3	100
3	9	4	50
3.5	9	4	50
4	10	4	50
4	16	4	75
4	20	4	100
5	13	5	50
5	20	5	75
5	25	5	100
5	13	6	50
6	15	6	50
6	24	6	75
6	30	6	100
6	40	6	150
8	20	8	60
8	30	8	75
8	35	8	100
8	50	8	150
10	25	10	75
10	40	10	100
10	60	10	150
12	30	12	75
12	45	12	100
12	60	12	150
14	40	14	100
14	70	14	150
16	45	16	100
16	75	16	150
18	45	18	100
18	75	18	150
20	45	20	100
20	75	20	150

刃径/D	刃长/H	柄径/d	全长/L
R0.5	2	4	50
R0.75	3	4	50
R1	4	4	50
R1.25	5	4	50
R1.5	6	4	50
R1.5	6	3	75
R1.5	6	3	100
R2	8	4	50
R2	8	4	75
R2	8	4	100
R2.5	10	5	50
R2.5	10	5	75
R2.5	10	5	100
R2.5	10	6	50
R3	12	6	50
R3	12	6	75
R3	12	6	100
R3	12	6	150
R4	16	8	60
R4	16	8	75
R4	16	8	100
R4	16	8	150
R5	20	10	75
R5	20	10	100
R5	20	10	150
R6	24	12	75
R6	24	12	100
R6	24	12	150
R7	28	14	100
R7	28	14	150
R8	32	16	100
R8	32	16	150
R9	36	18	100
R9	36	18	150
R10	40	20	100
R10	40	20	150

刃径/D	刃长/H	柄径/d	全长/L
D1R0.2	3	4	50
D1.5R0.2	4.5	4	50
D2R0.2	6	4	50
D2R0.5	6	4	50
D3R0.2	8	4	50
D3R0.5	8	4	50
D3R1	8	4	50
D4R0.2	10	4	50
D4R0.5	10	4	50
D4R0.5	10	4	75
D4R0.5	10	4	100
D4R1	10	4	50
D4R1	10	4	75
D4R1	10	4	100
D6R0.2	15	6	50
D6R0.5	15	6	50
D6R0.5	15	6	75
D6R0.5	15	6	100
D6R1	15	6	50
D6R1	15	6	75
D6R1	15	6	100
D8R0.5	20	8	60
D8R0.5	20	8	75
D8R0.5	20	8	100
D8R1	20	8	60
D8R1	20	8	75
D8R1	20	8	100
D10R0.5	25	10	75
D10R0.5	25	10	100
D10R1	25	10	75
D10R1	25	10	100
D12R0.5	30	12	75
D12R0.5	30	12	100
D12R1	30	12	75
D12R1	30	12	100

刃径/D	刃长/H	柄径/d	全长/L
1	3	4	50
1	4	4	75
1	5	4	100
1.5	4.5	4	50
1.5	6	4	75
1.5	7	4	100
2	6	4	50
2	8	4	75
2	10	4	100
2.5	7.5	4	50
2.5	10	4	75
3	9	3	50
3	12	3	75
3	15	3	100
3	9	4	50
3	12	4	75
3	15	4	100
3.5	10	4	50
4	12	4	50
4	16	4	75
4	20	4	100
5	15	5	50
5	20	5	75
5	25	5	100
5	15	5	50
6	18	6	50
6	24	6	75
6	30	6	100
6	45	6	150
6	45	6	150
8	24	8	60
8	30	8	75
8	35	8	100
8	50	8	150
8	70	8	200
10	30	10	75
10	40	10	100
10	60	10	150
10	70	10	200
12	35	12	75
12	45	12	100
12	60	12	150
12	70	12	200
14	45	14	100
14	70	14	150
16	45	16	100
16	70	16	150
16	100	16	200
18	45	18	100
18	70	18	150
20	45	20	100
20	70	20	150
20	100	20	200

刃径/D	刃长/H	柄径/d	全长/L
R0.5	2	4	50
R0.75	3	4	50
R1	4	4	50
R1.25	5	4	50
R1.5	6	4	50
R1.5	6	4	75
R1.5	6	4	100
R2	8	4	50
R2	8	4	75
R2	8	4	100
R2.5	10	5	50
R2.5	10	5	75
R2.5	10	5	100
R2.5	10	6	50
R3	12	6	50
R3	12	6	75
R3	12	6	100
R3	12	6	150
R4	16	8	60
R4	16	8	75
R4	16	8	100
R4	16	8	150
R5	20	10	75
R5	20	10	100
R5	20	10	150
R6	24	12	75
R6	24	12	100
R6	24	12	150
R7	28	14	100
R7	28	14	150
R8	32	16	100
R8	32	16	150
R9	36	18	100
R9	36	18	150
R10	40	20	100
R10	40	20	150

刃径/D	刃长/H	柄径/d	全长/L
1	3	4	50
1.5	5	4	50
2	6	4	50
2.5	8	4	50
3	9	3	50
3	12	3	75
3	15	3	100
3	9	4	50
3.5	10	4	50
4	12	4	50
4	16	4	75
4	20	4	100
5	15	5	50
5	20	5	75
5	25	5	100
5	15	6	50
6	18	6	50
6	24	6	75
6	30	6	100
6	45	6	150
8	24	8	60
8	30	8	75
8	35	8	100
8	50	8	150
10	30	10	75
10	40	10	100
10	55	10	150
12	35	12	75
12	45	12	100
12	55	12	150
14	45	14	100
14	70	14	150
16	45	16	100
16	80	16	150
18	45	18	100
18	80	18	150
20	45	20	100
20	80	20	150

◎2F-HRC60小径铣刀-纳米涂层

2F-HRC60 Micro End mill-Nano coating

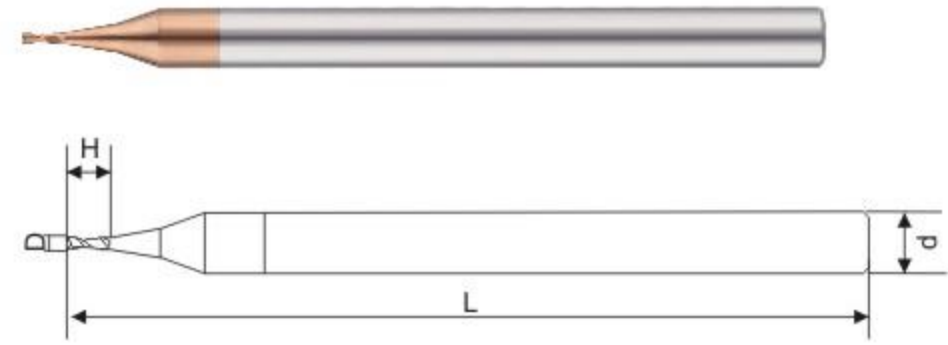

刃径/D	刃长/H	柄径/d	全长/L
0.1	0.2	4	50
0.2	0.4	4	50
0.3	0.6	4	50
0.4	0.8	4	50
0.5	1	4	50
0.6	1.2	4	50
0.7	1.4	4	50
0.8	1.6	4	50
0.9	1.8	4	50

◎2F-HRC60小径球刀-纳米涂层

2F-HRC60 Micro Ball nose -Nano coating

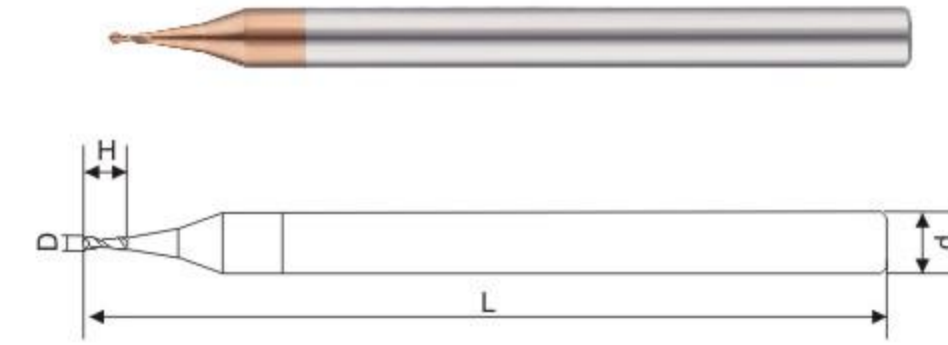

刃径/D	刃长/H	柄径/d	全长/L
R0.05	0.2	4	50
R0.1	0.4	4	50
R0.15	0.6	4	50
R0.2	0.8	4	50
R0.25	1	4	50
R0.3	1.2	4	50
R0.35	1.4	4	50
R0.4	1.6	4	50
R0.45	1.8	4	50

◎2F-HRC60深沟铣刀

2F-HRC60 Longneck end mill

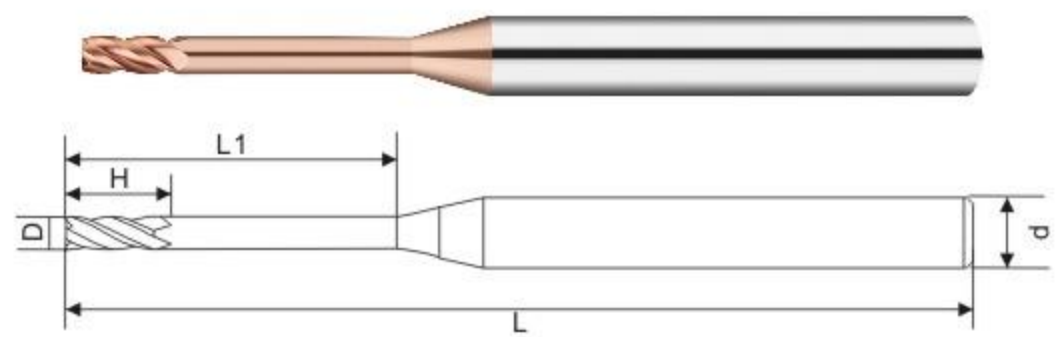

刃径/D	刃长/H	长颈/L1	柄径/d	全长/L
0.5	1	2	4	50
0.5	1	4	4	50
0.5	1	6	4	50
0.5	1	8	4	50
0.5	1	10	4	50
1	3	6	4	50
1	3	8	4	50
1	3	10	4	50
1	3	12	4	50
1	3	15	4	50
1	3	20	4	50
1.5	4.5	6	4	50
1.5	4.5	8	4	50
1.5	4.5	10	4	50
1.5	4.5	12	4	50
1.5	4.5	15	4	50
1.5	4.5	20	4	50
2	6	8	4	50
2	6	10	4	50
2	6	12	4	50
2	6	15	4	50
2	6	20	4	50
2.5	7.5	10	4	50
2.5	7.5	12	4	50
2.5	7.5	15	4	50
2.5	7.5	20	4	50
3	9	12	4	50
3	9	15	4	50
3	9	20	4	50

◎2F-HRC60深沟球刀

2F-HRC60 Long neck Ballnose

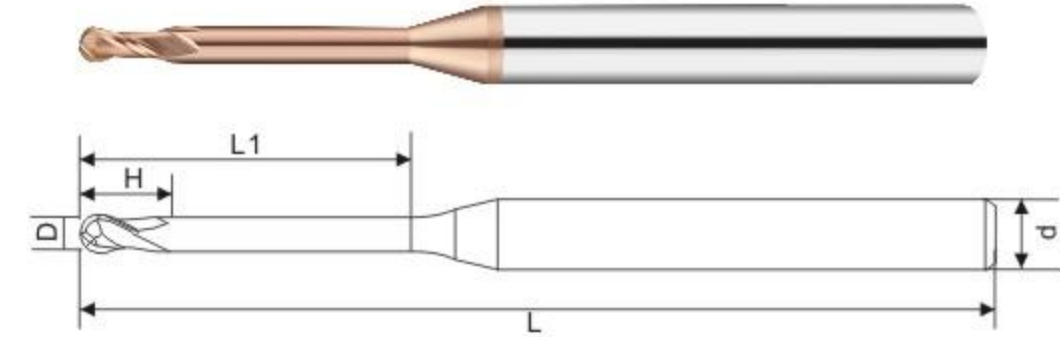

刃径/D	刃长/H	长颈/L1	柄径/d	全长/L
R0.25	1	2	4	50
R0.25	1	4	4	50
R0.25	1	6	4	50
R0.25	1	8	4	50
R0.25	1	10	4	50
R0.5	2	6	4	50
R0.5	2	8	4	50
R0.5	2	10	4	50
R0.5	2	12	4	50
R0.5	2	15	4	50
R0.5	2	20	4	50
R0.75	3	6	4	50
R0.75	3	8	4	50
R0.75	3	10	4	50
R0.75	3	12	4	50
R0.75	3	15	4	50
R0.75	3	20	4	50
R1	4	8	4	50
R1	4	10	4	50
R1	4	12	4	50
R1	4	15	4	50
R1	4	20	4	50
R1.25	5	10	4	50
R1.25	5	12	4	50
R1.25	5	15	4	50
R1.25	5	20	4	50
R1.5	6	12	4	50
R1.5	6	15	4	50
R1.5	6	20	4	50

◎4F-钢用粗皮刀

4F-Coated Rough End mill

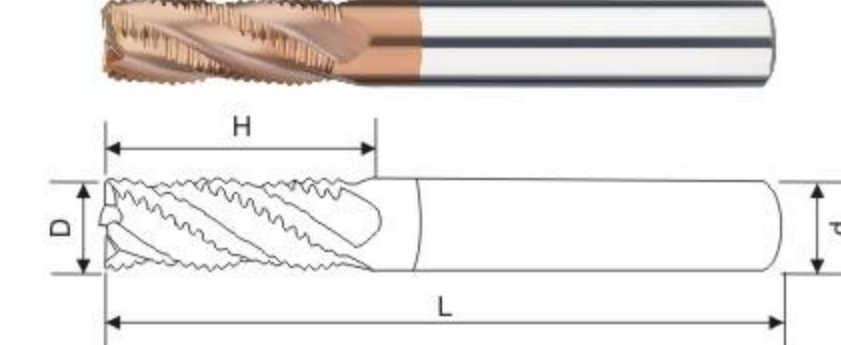

刃径/D	刃长/H	柄径/d	全长/L
4	10	4	50
5	13	5	50
6	15	6	50
6	30	6	100
8	20	8	60
8	35	8	100
10	25	10	75
10	40	10	100
10	60	10	150
12	30	12	75
12	45	12	100
12	60	12	150
14	45	14	100
14	70	14	150
16	45	16	100
16	75	16	150
18	45	18	100
18	75	18	150
20	45	20	100
20	75	20	150

◎3F-铝用粗皮刀

3F-Aluminum Rough Endmill

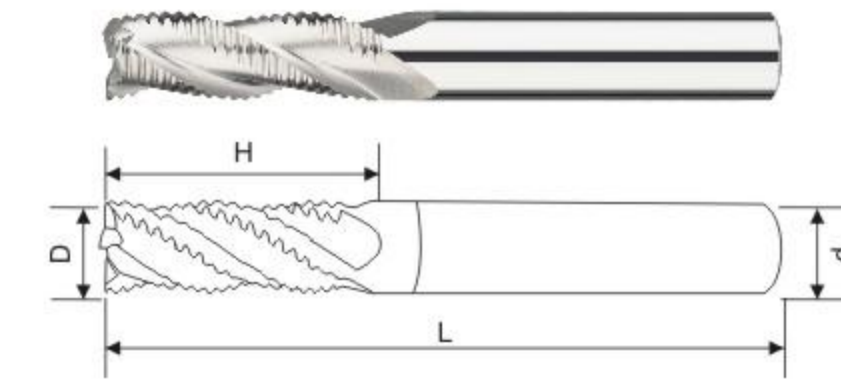

刃径/D	刃长/H	柄径/d	全长/L
4	10	4	50
5	13	5	50
6	15	6	50
6	30	6	100
8	20	8	60
8	35	8	100
10	25	10	75
10	40	10	100
10	60	10	150
12	30	12	75
12	45	12	100
12	60	12	150
14	45	14	100
14	70	14	150
16	45	16	100
16	75	16	150
18	45	18	100
18	75	18	150
20	45	20	100
20	75	20	150

◎T型铣刀

T-type Endmill

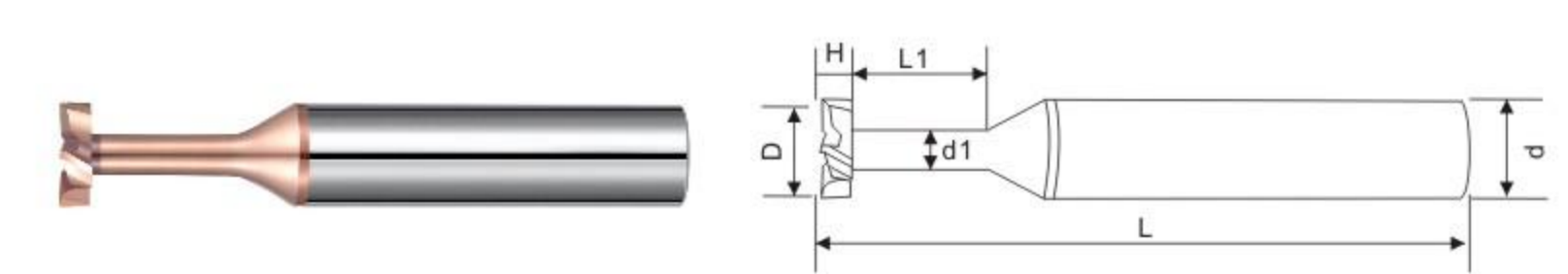

刃径/D	刃长/H	避空径/d1	碧空长/L1	柄径/d	全长/L
4	0.5	1.5	6	4	50
4	1	1.5	6	4	50
4	1.5	1.5	6	4	50
4	2	1.5	6	4	50
4	3	1.5	6	4	50
6	0.5	2.5	10	6	50
6	1	2.5	10	6	50
6	1.5	2.5	10	6	50
6	2	2.5	10	6	50
6	3	2.5	10	6	50
6	4	2.5	10	6	50
8	0.5	3.5	12	8	60
8	1	3.5	12	8	60
8	1.5	3.5	12	8	60
8	2	3.5	12	8	60
8	3	3.5	12	8	60
8	4	3.5	12	8	60
10	0.5	4	15	10	75
10	1	4	15	10	75
10	1.5	4	15	10	75
10	2	4	15	10	75
10	3	4	15	10	75
10	4	4	15	10	75
10	5	4	15	10	75
12	0.5	5	15	12	75
12	1	5	15	12	75
12	1.5	5	15	12	75
12	2	5	15	12	75
12	3	5	15	12	75
12	4	5	15	12	75
12	5	5	15	12	75

◎燕尾刀

Carbide dovetail Cutter

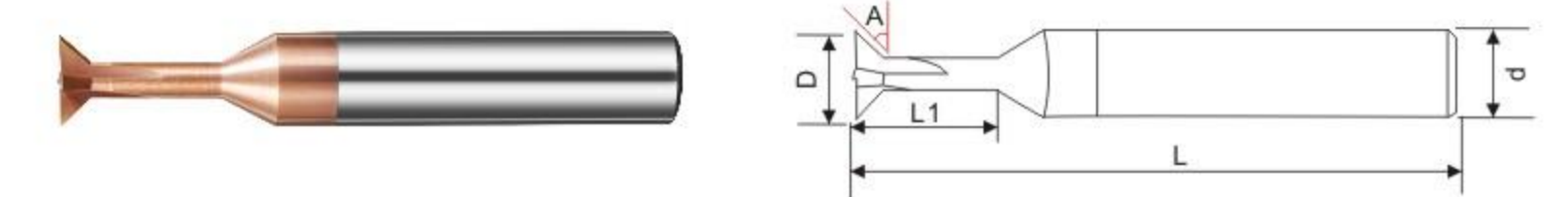

刃径/D	角度/A	避空长度/L1	柄径/d	全长/L
3	60°/90°/120°	6	4	50
4	60°/90°/120°	8	4	50
6	60°/90°/120°	10	6	50
8	60°/90°/120°	12	8	60
10	60°/90°/120°	15	10	75
12	60°/90°/120°	18	12	75

◎2F-定点钻

2F-Spot Drill

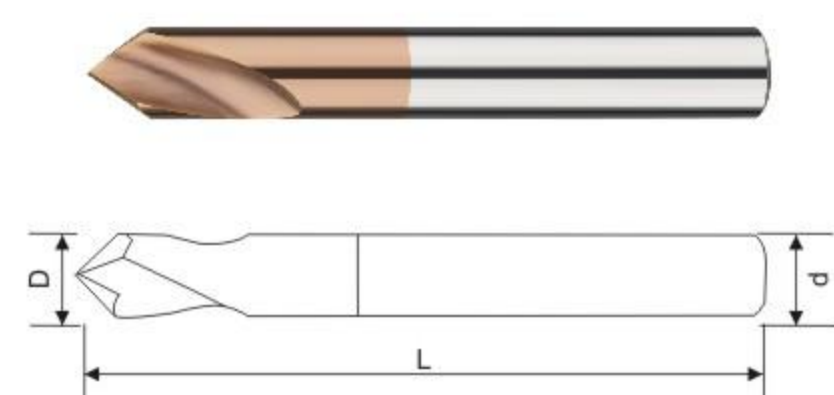

刃径/D	角度/A	柄径/d	全长/L
1	60°/90°/120°	4	50
1.5	60°/90°/120°	4	50
2	60°/90°/120°	4	50
2.5	60°/90°/120°	4	50
3	60°/90°/120°	4	50
3	60°/90°/120°	3	50
4	60°/90°/120°	4	50
4	90°	4	100
5	90°	5	50
6	60°/90°/120°	6	50
6	90°	6	100
8	60°/90°/120°	8	60
8	90°	8	100
10	60°/90°/120°	10	75
10	90°	10	100
12	60°/90°/120°	12	75
12	90°	12	100
14	90°	14	100
16	90°	16	100
18	90°	18	100
20	90°	20	100

◎3F-倒角刀

3F-Carbide Chamfer Drill

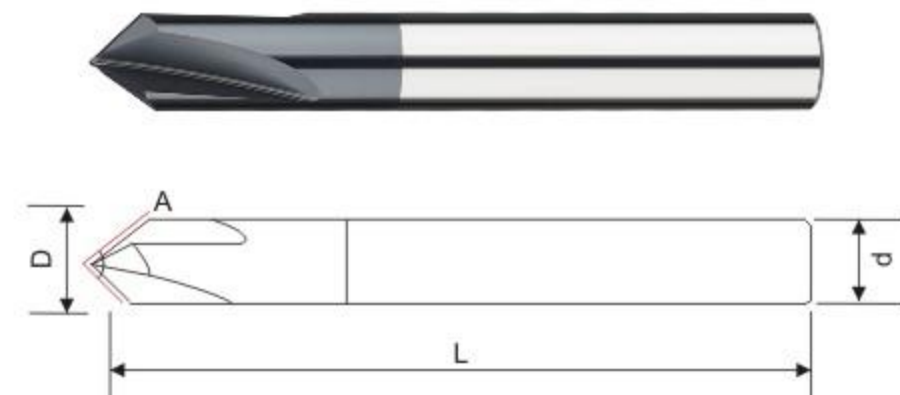

刃径/D	角度/A	柄径/d	全长/L
1	60°/90°/120°	4	50
1.5	60°/90°/120°	4	50
2	60°/90°/120°	4	50
2.5	60°/90°/120°	4	50
3	60°/90°/120°	4	50
3	60°/90°/120°	3	50
4	60°/90°/120°	4	50
4	90°	4	100
5	90°	5	50
6	60°/90°/120°	6	50
6	90°	6	100
8	60°/90°/120°	8	60
8	90°	8	100
10	60°/90°/120°	10	75
10	90°	10	100
12	60°/90°/120°	12	75
12	90°	12	100
14	90°	14	100
16	90°	16	100
18	90°	18	100
20	90°	20	100

◎内R刀

Inner R Cutter



刃径/D	R角/R	柄径/d	全长/L
4	0.5	4	50
4	0.75	4	50
4	1	4	50
6	1	6	50
6	1.5	6	50
6	2	6	50
6	2.5	6	50
8	2.5	8	60
8	3	8	60
10	4	10	75
12	5	12	75

◎钨钢抗震车刀杆

Carbide tool holder

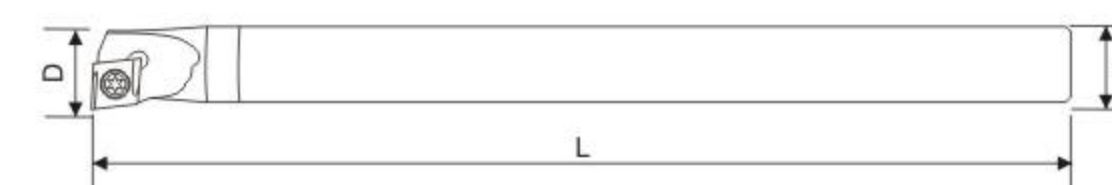

型号 Code	搭配刀片型号 Matching blade type	最小加工直径 Minimum machining diameter	长度 Length	柄径 Shank diameter	
C04H-SCLCR03	CCGT030102L	5	100	4	
C05H-SCLCR03	CCGT030104L	6	100	5	
C06K-SCLCR06	CCGT060204 CCMT060204	8.5	125	6	
C07K-SCLCR06		9	125	7	
C08K-SCLCR06		10	125	8	
C10K-SCLCR06		12.5	125	10	
C12M-SCLCR06	CCGT09T304 CCMT09T304	14.5	150	12	
C12M-SCLCR09		15	150	12	
C14N-SCLCR09		17	160	14	
C14Q-SCLCR09		17	180	14	
C16Q-SCLCR09		19	180	16	
C18Q-SCLCR09		21	180	18	
C20Q-SCLCR09		23	180	20	
C20R-SCLCR09		23	200	20	
C25R-SCLCR09		28	200	25	
C25S-SCLCR09		28	250	25	
C32T-SCLCR09	36	300	32		
<hr/>					
C08K-SDUCR/L07	DC□□0702□□	13	125	8	
C10K-SDUCR/L07		15	125	10	
C12M-SDUCR/L07		17	150	12	
C14N-SDUCR/L07		17	160	14	
C16Q-SDUCR/L07		21	180	16	
C16Q-SDUCR/L11	DC□□11T3□□	21	180	16	
C18Q-SDUCR/L11		24	180	18	
C20R-SDUCR/L11		28	200	20	
C25S-SDUCR/L11		35	250	25	
C32T-SDUCR/L11		42	300	32	
<hr/>					
C08K-STUCR/L09		TC□□0902□□	10.5	125	8
C10K-STUCR/L09	TC□□1102□□	13.5	125	10	
C10K-STUCR/L11		13.5	125	10	
C12M-STUCR/L11		16	150	12	
C16Q-STUCR/L11		20	180	16	
<hr/>					
C08K-STUPR/L09	TP□□0902□□	11	125	8	
C10K-STUPR/L09	TC□□1103□□	13	125	10	
C10K-STUPR/L1103		13	125	10	
C12M-STUPR/L1103		16	150	12	
C16N-STUPR/L1103		20	160	16	

可以来图来样非标定制!
Non-standard size can be done
according to your drawing

Blank page with horizontal dashed lines for writing.

Blank page with horizontal dashed lines for writing.